



RZ-3 egg breaker

Description

Capacity: 9600 eggs/hour

Replaces: 22 people

Power supply: 1 kW 230 V 1/N/PE 50/60 Hz
1 kW 110 V 1/N/PE 50/60 Hz

Dimensions: 1805x936x1061 mm

Minimal workspace: 2500x2500 mm

Compressed air: 5.5-8 bar, min. flow 260 l/min.

Weight: 180 kg

Water: n/a

Operated by: 2 persons

Drain: n/a

Compatibility: VEL-30, MT-3, UVC-3, ESS, UZS, PS-2, FS

The egg breaker imitates the work of human hands by cracking the eggshells with the use of special knives. Next, the cracked eggs slide down a separator, where yolks are separated from egg whites. This most hygienic egg breaking method is an innovation by OVO-TECH. The machine is made out of stainless steel EN 1.4301 (AISI 304).

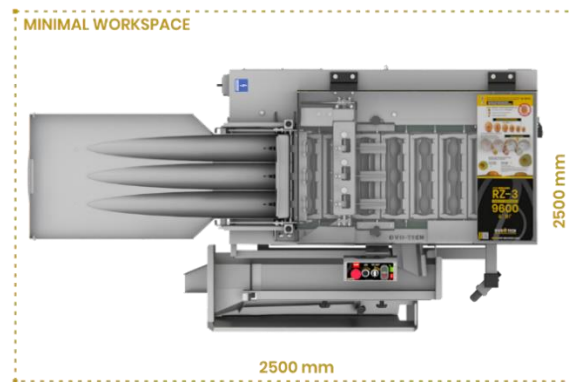
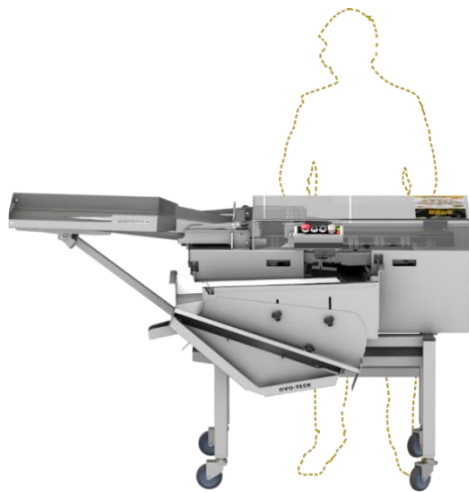

DATE: 20.01.2021
 PROJECT: DOK-LAY EN E.2.1
 AUTHOR: ML

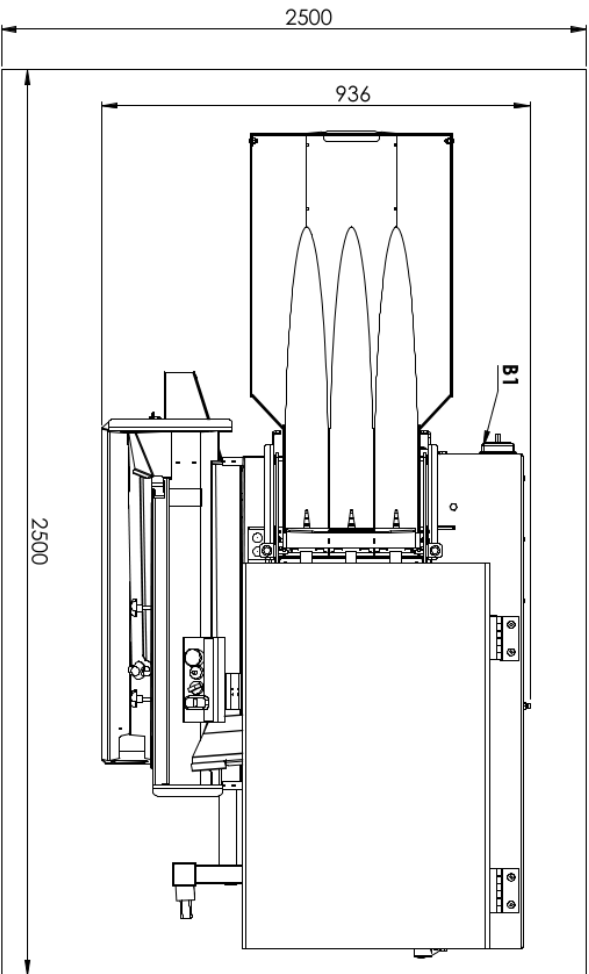
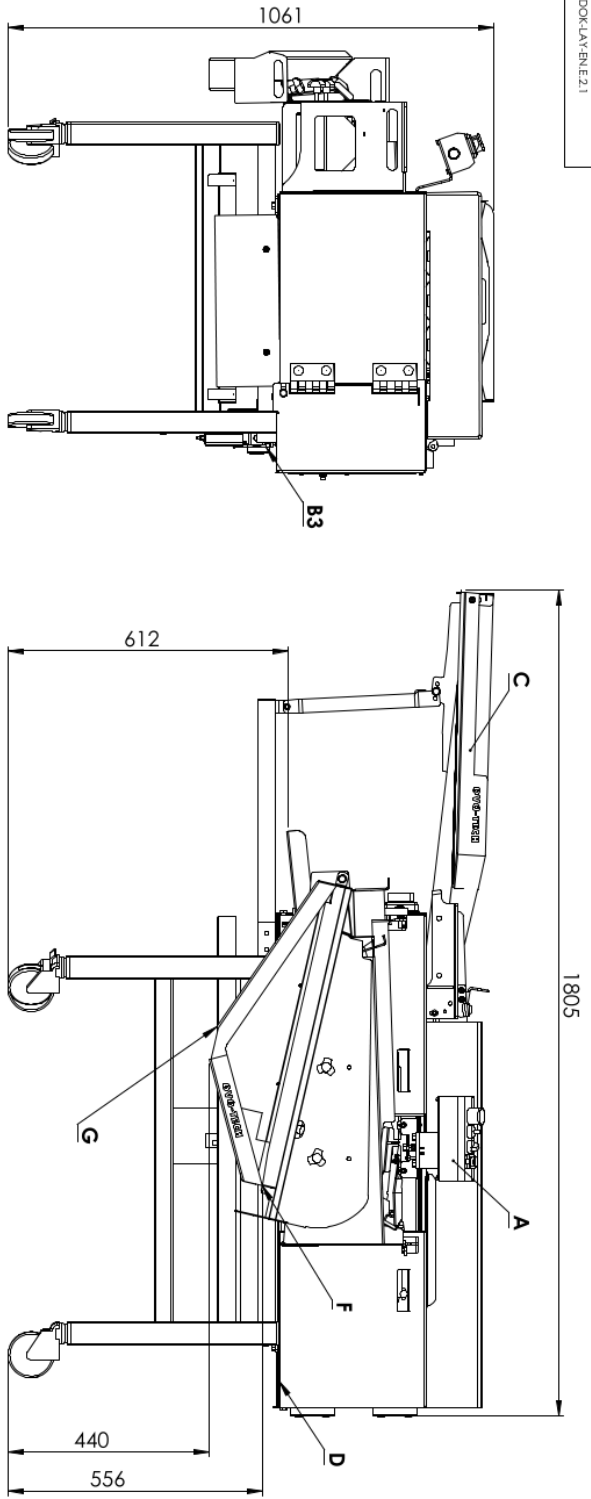

All rights reserved.
 This document is the property of OVO-TECH.
 Any use of this product, including
 reproduction, is prohibited without O's written permission & strictly
 prohibited.

RZ-3 egg breaker

Typical workplaces:	egg breaking facilities, bakeries, confectioneries, pasta making companies
Capacity:	9000 eggs/hour
Power supply:	1 kW 230 V 1/IN/PE 50/60 Hz 1 kW 110 V 1/IN/PE 50/60 Hz
Water connection:	N/A
Compressed air connection:	5-5.8 bar, minimal flow 250 liters/hour
Minimal workspace:	2500 x 2500 mm
Dimensions:	1805 x 936 x 1067 mm
Operated by:	2 persons
Minimal wall clearance:	the rear side - 600 mm
Additional information:	N/A
A B1/B2/B3 C E F G	control panel connection: electrical/water/air eggs input eggs/whites outlet eggs/yolks outlet egg white outlet